



Series 200

Self-Contained Flake Ice Machine



Features:

- Great performance
- Quality flake ice
- Production up to 200 lb (91 kg) per day
- Bin Capacity 75 lb (34 kg)
- Environmentally safe
- R404a Refrigerant
- Energy efficient - lower cost - long life
- Continuous ice making
- One single moving part
- Top mounted drive system
- Compact space saving design
- Low profile
- Requires only 4 sq. ft.
- Gray baked enamel exterior or optional stainless steel
- Polyethylene bin



Series 200

Technical Specifications:

Condenser: Air-cooled

Circuit Capacity: 15A

Maximum fuse size: 5A

Operating Weight: 190 lb (86 kg)

Ice Storage Capacity: 75 lb (34 kg)

Refrigerant type: R-404av

Ambient temperature: 50°F (10°C) -100°F (38°C)

Shipping Weight: 220 lb (100 kg)

Water temperature: 50°F/10°C - 90°F/32°C

Water pressure: 20-120 psi

Agency Listings:

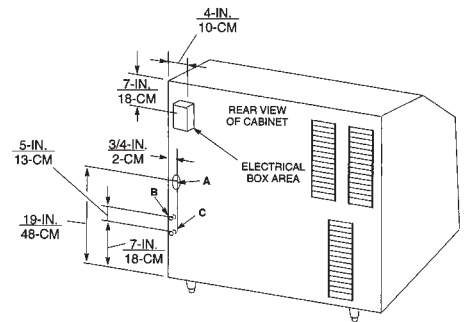
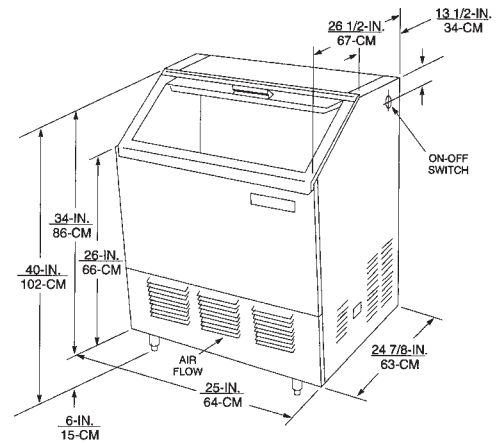

A – 1/4 WATER INLETS (S.A.E. MALE FLARE)
 B – 5/8 O.D. TUBE (DRAIN)
 C – 1/2 O.D. TUBE (DRAIN)

AF-200-P(S)-SCR PRODUCTION CHART			
AIR TEMPERATURE	WATER TEMPERATURE		
	50°F/10°C	70°F/21°C	80°F/27°C
50°F/10°C	219 lb/99 kg	188 lb/85 kg	175 lb/79 kg
70°F/21°C	208 lb/95 kg	174 lb/79 kg	166 lb/75 kg
90°F/32°C	161 lb/35 kg	130 lb/59 kg	117 lb/53 kg

AF-200-P-SC50R PRODUCTION CHART			
AIR TEMPERATURE	WATER TEMPERATURE		
	50°F/10°C	70°F/21°C	80°F/27°C
50°F/10°C	234 lb/106 kg	206 lb/94 kg	197 lb/90 kg
70°F/21°C	213 lb/97 kg	190 lb/86 kg	180 lb/82 kg
90°F/32°C	183 lb/83 kg	164 lb/75 kg	156 lb/71 kg

Model No.	Description	Cabinet	Electrical	Voltage
AF200-P-SCR	200 Self-Contained Flaker	Enamel	115/V/60Hz/1	110-126V
AF200-S-SCR	200 Self-Contained Flaker	Stainless	115/V/60Hz/1	110-126V
AF200P-SC50R	200 Self-Contained Flaker	Enamel	220/V/50Hz/1	209-264V



For more information
 or to place an order,
 contact your sales
 representative or
 authorized distributor.

Phone: 1-800-238-3600
 Fax: 1-800-535-4235

www.cornelius.com